

ARTICLE

LitePoint's Complete Guide to 5G OTA Testing

UPDATED: MAY 20, 2019

LITEPOINT

© 2019 LitePoint, A Teradyne Company.
All rights reserved.



Introduction

To help engineers navigate the challenges of 5G OTA testing, LitePoint has put together this comprehensive guide to 5G OTA testing, featuring articles previously published at EDN, Microwaves & RF and RF Globalnet.



Link-budget Calculations: Needed for 5G OTA Testing (page 3)

In his article at EDN, LitePoint's George Hurtarte explores how to calculate the total link budget for OTA test.



Over-the-Air Testing for 5G mmWave Devices: DFF or CATR? (page 8)

At Microwaves & RF Hurtarte and LitePoint's Middle Wen explain the differences between DFF and CATR chambers and the tradeoffs in cost and path-loss performance between the two types of chambers.



Understanding 5G Millimeter Wave Beamforming Test (page 14)

Finally, in the article at RF Globalnet, George Hurtarte and LitePoint's Vito Liao explain beamforming in the context of 5G NR specifications, and introduces beamforming characterization and beamforming verification test.

Link-budget Calculations: Needed for 5G OTA Testing

Previously published at EDN on January 22, 2019

5G millimeter wave (mmWave) devices operating above 24 GHz incorporate millimeter-sized patch antenna arrays or dipole antennas that become an integral part of the device module packaging. Testing these assemblies requires over-the-air tests inside a chamber. But, a mmWave test chamber can introduce significant path loss, more than from cables and connectors. Understanding how to calculate the total link budget for over-the-air testing is a critical step in 5G mmWave OTA test.

Each patch antenna element in a 5G mobile or fixed-access device can transmit or receive electromagnetic waves in either the vertical or horizontal direction. Figure 1 shows the simulated antenna pattern of a 3x3 patch antenna array. The different colors show the intensity of the radiated power, with red indicating the highest power and blue the lowest.

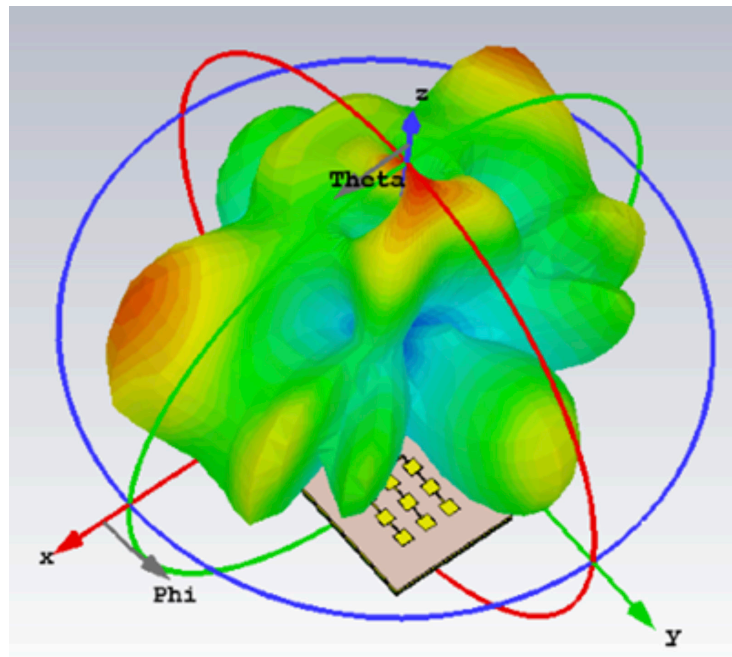

Figure 1. Simulated antenna pattern of a 3x3 patch-antenna array shows field strength of the radiated waves.

Because mmWave modules containing patch-antenna arrays and dipole antennas are an integral part of the end-user product, the only way to characterize and test the performance of the antennas is through over the air (OTA) testing. Unlike wireless products operating at sub-6 GHz frequencies, mmWave products introduce a new test challenge related to OTA testing.

Data path losses

Over-the-air path losses (measured in dB) can be significant at mmWave frequencies relative to contacted cable and connector losses. For example, a 2.92 mm connector-cable assembly can have a path loss of about 2.75 dB/m at 40 GHz, whereas the over-the-air path loss at the same frequency is about 64 dB at an over-the-air distance of 1 m.

The following Friis equation lets you calculate the OTA path losses when the distance R between the transmitting and receiving antennas are equal or greater to the far-field (FF) region:

$$OTA \text{ Path Loss (dB)} = 10 \log_{10} \left(\frac{\lambda^2}{(4\pi R)^2} \right)$$

Where λ is the wavelength in meters and R is equal or greater than the far-field region distance as explained next. The far-field distance R is the distance at which the spherical waves can be considered as a "plane" wave at the receiving antenna, thus fulfilling the following mathematical requirement:

$$R \geq \frac{2D^2}{\lambda}$$

Where D is the largest dimension of the apertures (that is, the maximum effective size of the antenna) of either the transmitting (D1) or receiving (D2) antennas as shown in Figure 2.

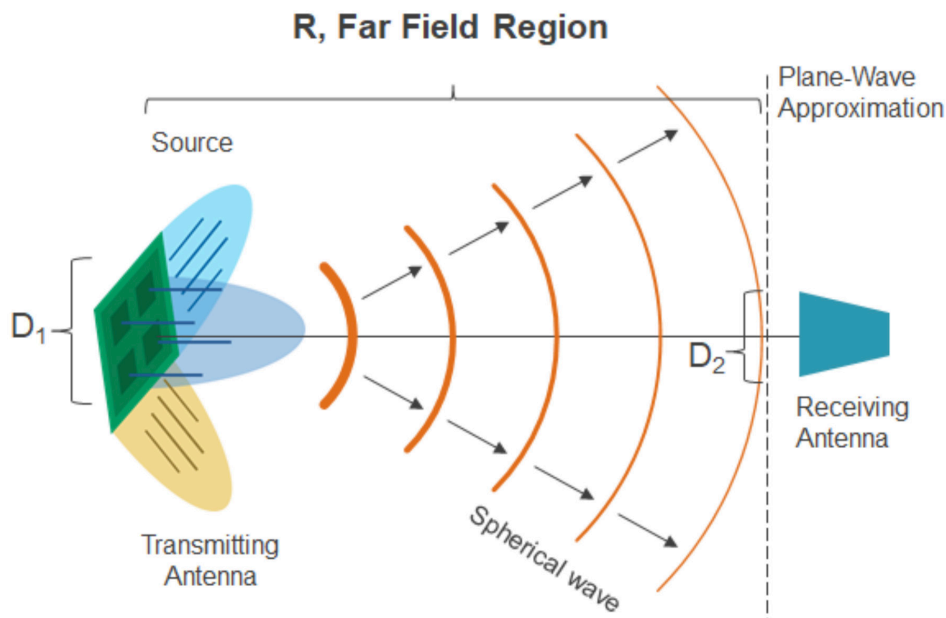

Figure 2. The transmitting and receiving antennas as separated by far-field distance R.

The choice of a known-performance horn antenna as the test antenna in Figure 2 illustrates the typical OTA measurement environment in the R&D lab, DVT and manufacturing test setups. Figure 2 shows the device-under-test (DUT) radiating electromagnetic waves energy over-the-air and a test horn antenna receiving the much-attenuated energy which in turn is amplified by its own gain (for example, 15 dBi or 20 dBi of gain). Thus, at 40 GHz, an OTA path loss of 60 dB will become $-60 \text{ dB} + 15 \text{ dB} = -45 \text{ dB}$ at the output of a 15 dBi horn antenna. Thus, the choice of a measuring horn antenna with known gain is a key OTA test set up decision.

There is, however, a tradeoff between horn antenna gain and the fair field distance R . The higher the horn antenna gain, the larger its aperture D and thus the larger the far field distance R . For example, a typical single polarization 15 dBi-gain antenna has $D = 26.1 \text{ mm}$, which translates to a far field distance $R = 182.3 \text{ mm}$; whereas a 20 dBi-gain antenna has $D = 51.5 \text{ mm}$, which translates to a far field distance $R = 706.6 \text{ mm}$, an increase of about half a meter in distance. This half-meter increase in far field distance will result in an additional 11.8 dB of OTA path losses thus more than offsetting the higher horn antenna gain.

Thus, the larger the measuring horn antenna gain, the larger the D , the larger the R and thus the larger the OTA chamber required and, the larger the R distance, the larger the OTA path losses. Thus, clearly, various technical tradeoffs must be decided when designing OTA chambers as the over-the-air path losses can be significant.

Figure 3 shows a 60-cm far-field distance (R) OTA chamber for testing of mmWave devices.



Figure 3. 60-cm far-field OTA chamber isolates mmWave signals from the ambient electromagnetic environment.

OTA link budget calculations

Calculating the total OTA test chamber link budget is of critical importance for making accurate DUT antenna measurements. The resulting link budget net loss needs to be combined with the measurements made by the mmWave tester instrument to determine the actual radiated power and phase being generated by the each of the DUT antenna array elements, or, likewise, when generating mmWave signals from the test horn antenna into the DUT.

Once the choices have been made for a DUT antenna array size with aperture D1, a chamber test horn antenna with aperture D2, and a chamber with a far-field distance R (such as the chamber shown in Fig. 3), Friis transmission equation can be used to calculate the overall link budget of the OTA test set up.

Figure 4 shows the setup variables required to calculate the OTA link budget using the Friis equation.



Figure 4. Setup variables required to calculate the OTA link budget using Friis equation.

$$P_R = G_R G_T P_T \frac{\lambda^2}{(4\pi R)^2}$$

Where:

PR = Power at the receiving antenna

GR = Gain of the receiving antenna

PT = Power at the transmitting antenna

GT = Gain of the transmitting antenna

λ = Wavelength of the operating frequency

R = Far-field distance between the two antennas

You must also take into account the insertion loss of cables and connectors when calculating. Whereas connector insertion losses are relatively small—in the range of 0.3 dB—typical 2.92 mm cable losses can add up at a rate of 2.75 dB per meter at 40 GHz. For a total cable length of 1.5 m, the cable insertion loss is in the range of 4 dB, which is only about 6% of the total link losses at 40 GHz. The OTA path loss represents 94% of the total path losses as seen in the example of Table 1.

Frequency	40 GHz	
TX antenna Gain, G_T	5 dBi	
RX antenna gain, G_R	15 dBi	
OTA Distance R	0.6 m	Path Loss %
OTA Pathloss, PL	-60.0 dB	94%
Total cable length	1.5 m	
Total cable loss	-4.1 dB	6%

TX Case	
Device TX, P_T	0 dBm
Tester RX, P_R	-44.2 dBm

RX Case	
Tester TX, P_T	10 dBm
Device RX, P_R	-34.2 dBm

Table 1. OTA chamber link budget calculation example

Table 1 shows an example of a link budget calculation for a 60-cm far-field chamber at 40 GHz with a total cable length of 1.5 m, a test horn antenna with 15 dBi of gain, and a DUT antenna with 5 dBi of gain. In the TX Case, Friis transmission equation yields an adjusted $P_R = -44.2$ dBm at the tester instrument input, taking into account the cable loss. Table 1 also shows the reverse case when the tester is transmitting through the test horn antenna into the DUT. In the RX Case, the DUT would be receiving -34.2 dBm at its patch antenna array or dipole antenna when the tester output power is set at 10 dBm. Having a good understanding of 5G link budget calculations is a critical step toward ensuring a proper OTA test set up as it drives the selection of the appropriate test horn antennas, cables, connectors and tester power settings.

Having a good understanding of 5G link budget calculations is a critical step toward ensuring a proper OTA test set up as it drives the selection of the appropriate test horn antennas, cables, connectors and tester power settings.

Over-the-Air Testing for 5G mmWave Devices: DFF or CATR?

Previously published at Microwaves & RF on February 13, 2019

With the advent of 5G millimeter-wave (mmWave) devices of various sizes and applications, each requiring different architectures and sizes of mmWave antennas, it's critical for test engineers to understand the differences in over-the-air (OTA) test chambers and test techniques. Direct far field (DFF) and compact antenna test range (CATR) are two types of OTA test methods supported by the 3GPP TR 38.810 Study on Test Methods for 5G FR2 (mmWave bands) devices.

Since CATR OTA chambers can cost up to 10 times more than DFF chambers, a test engineer must decide which one is best suited for the intended application and test requirements. Here, we will explain the differences between DFF and CATR chambers and the tradeoffs in cost and path-loss performance between the two types of chambers.

Introduction

5G mmWave devices operating above 24 GHz incorporate millimeter-sized antenna arrays or dipole antennas, which become an integral part of the device module packaging. Thus, the only way to characterize and test the performance of the antennas as part of the final product is via OTA testing.

Figure 1 shows a user-equipment (UE) device (i.e., smartphone) with two built-in 5G mmWave modules, each containing a 1-x-4 patch antenna array and four dipole antennas. For this discussion, we will consider either the module or the final product as the device under test (DUT). For the example shown, each patch antenna element can have a vertical (V) or horizontal (H) polarization radiation pattern, which transmits or receives electromagnetic (EM) waves in either the vertical or horizontal direction.

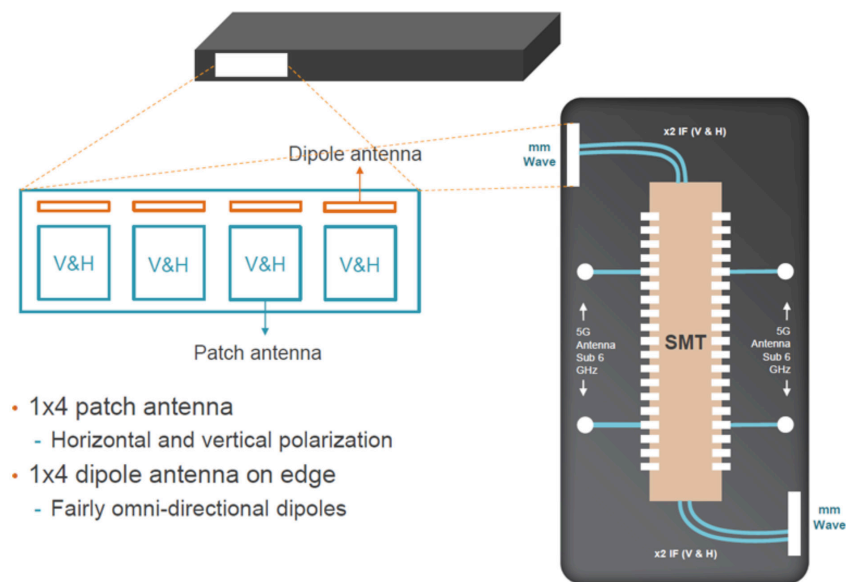

Figure 1. This user-equipment device is fitted with mmWave antennas.

When the antenna module is inside the final product, say, the smartphone, the antenna radiation pattern can be altered slightly due to the interaction with the final product enclosure materials and other surrounding components. Thus, the antenna performance, including its beamforming characteristics, needs to be tested using an appropriate OTA chamber of size, architecture, and shielding performance that ensures accurate antenna-radiation-pattern measurements.

5G mmWave OTA Test Methods

The 3GPP standards organization has published a technical document, TR 38.810, on 5G NR test methods.¹ It has declared that for UE RF test methods at mmWave frequencies, the following general aspects apply:

- OTA measurement is the testing methodology
- Permitted test methods are:
 1. DFF
 2. Indirect far field (IFF), also known as CATR
 3. Near-field to far-field transform

The test engineer's choice of the appropriate test method (DFF versus CATR, for example) has major implications in terms of capital equipment cost. CATR OTA chambers can cost as much as 10 times more than DFF OTA chambers. For all OTA test methods explained below, it's the responsibility of the UE manufacturers to "declare the antenna array size."

Direct-Far-Field Test Method

Typically, the exact locations of the antenna modules inside the UE DUT are well known. The DUT radiating antenna aperture dimension (D) is also known (expressed in cm). From this dimension, the required far-field distance (R) that separates the DUT from the test horn antenna can be derived using well-known mathematical equations, as explained later.

Per the TR 38.810 permitted test methods, if $D \leq 5$ cm, the DFF test method can be used. This can translate to a significant OTA chamber capital cost savings. For example, a typical UE smartphone antenna module for UE smartphones, operating at both the 28- and 39-GHz frequency bands, has a D dimension of just below 3 cm—well within the " $D \leq 5$ cm" requirement for the DFF chamber test method.

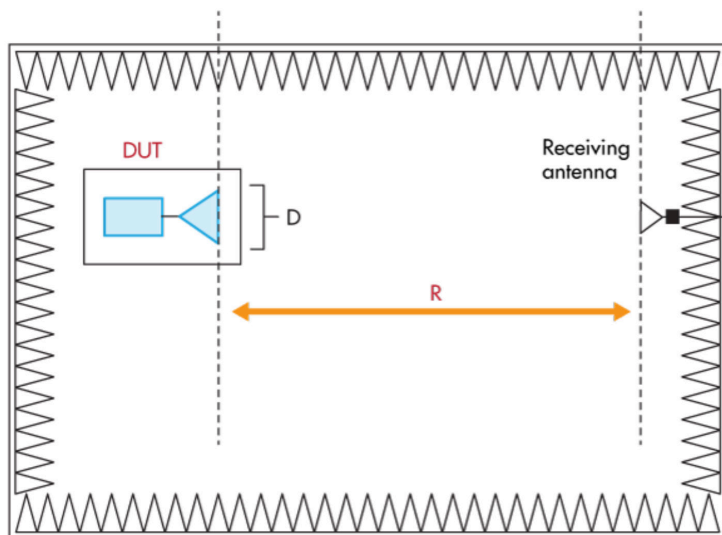

Figure 2. Here's a representation of a DFF OTA chamber. (Source: Ref. 2)

For DFF (Fig. 2), the far-field distance (R) is the minimum distance at which the spherical waves can be considered as a "plane" wave at the receiving test antenna, thus fulfilling the following mathematical requirement:

$$R \geq \frac{2D^2}{\lambda}$$

where D is the diameter of the smallest sphere that encloses the radiating part of the DUT.

For D = 5 cm, the above equation yields a minimum far-field distance (R) of about 47 cm at 28 GHz. With the above equation, it can be shown that a 60-cm DFF OTA chamber, such as the one shown in Figure 3, satisfies the DFF test method requirements for a final product that has 5G antenna modules with apertures (D) of up to 4.5 cm at frequencies up to 44 GHz. Therefore, for existing 5G mmWave modules with D in the range of 3 cm, the DFF OTA chamber is the most economical choice.



Figure 3. A 60-cm DFF OTA chamber is shown with LitePoint's IQgig-5G mmWave tester.

Indirect-Far-Field Test Method

The IFF test method creates the far-field environment using a transformation with a parabolic reflector. This is also known as CATR.

Inside the CATR chamber, the DUT radiates a wave front to a range-antenna reflector that then collimates the radiated spherical wave front into a receiver-feed antenna (Fig. 4). The separation between the DUT and the receiver is enough so that the emanating spherical wave reaches nearly plane phase fronts from transmitter to receiver.²

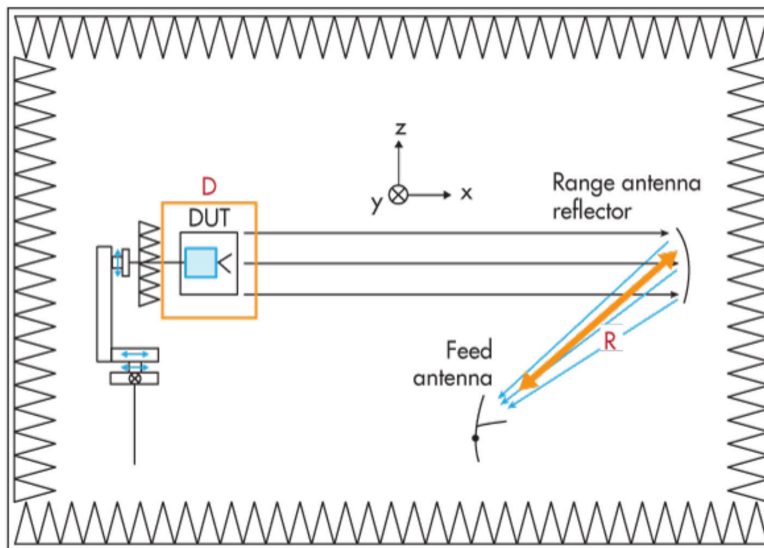

Figure 4. This drawing represents a CATR OTA chamber.

Per the 3GPP TR 38.810 document cited earlier, the CATR chamber test system does not require a measurement distance of:

$$R \geq \frac{2D^2}{\lambda}$$

to achieve a plane wave, as is the case with the DFF range. For CATR, the far-field distance (R) is seen as the focal length; that is, the distance between the “feed antenna” and the parabolic reflector. It’s calculated using the following equation:

$$R = 3.5 \times \text{size of reflector} = 3.5 \times (2D)$$

For $D = 5$ cm, the CATR far-field distance, or focal length, is $3.5 \times 2 \times 5 = 35$ cm, which allows for a more compact OTA chamber at the expense of a high-precision parabolic reflector.

Near-Field to Far-Field Transform Test Method

The near-field to far-field transform test method computes the performance metrics defined for far field by using mathematical near-field to far-field transformations. Thus, the UE radiated near-field beam patterns are measured first. Next these measurements are translated into far-field metrics using the near-field to far-field mathematical transform.

Per TR 38.810, the near-field to far-field transform test method is only applicable for DUTs with radiating apertures of $D \leq 5$ cm. A near-field to far-field transform test chamber can be smaller than DFF and CATR chambers, since the DUT is tested in the near field.

DFF vs. CATR OTA Path-Loss Comparison

As discussed in Ref. 3, OTA path losses can represent up to 94% of the total link budget in the OTA test setup. Thus, minimizing such path loss is of critical importance for the test engineer.

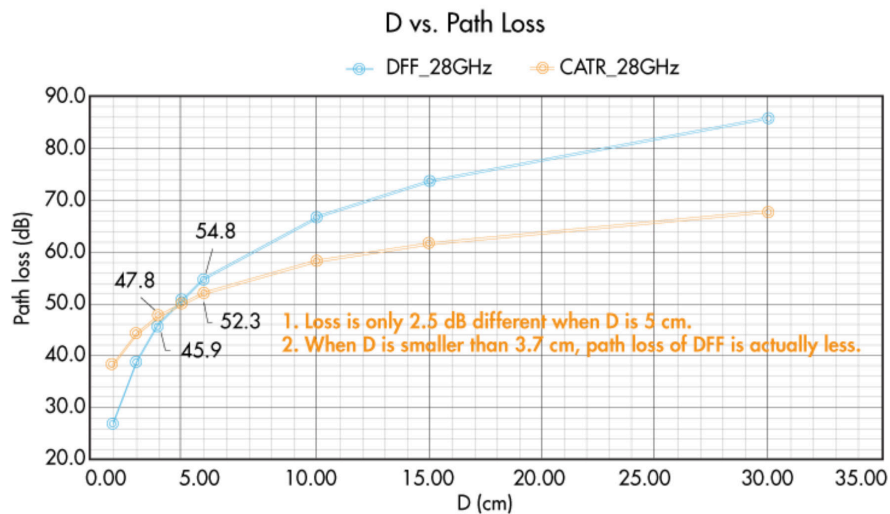

Figure 5. These plots compare DFF and CATR path loss at 28 GHz.

Figure 5 plots the path loss versus antenna aperture size (D) for both DFF and CATR OTA chambers. The path loss in dB is calculated using the Free Space Loss formula, with R = far-field distance:

$$\frac{\lambda^2}{(4\pi R)^2}$$

From Figure 5, at 28 GHz, the path loss is actually less for a DFF chamber when $D \leq 3.7$ cm as compared with the path loss of a CATR chamber. As mentioned earlier, typical 5G UE antenna array modules have an aperture D in the range of 3 cm. Thus, the DFF OTA chamber is a better choice than the CATR OTA chamber in terms of path loss for $D \leq 3.7$ cm.

Figure 6 compares the OTA path loss at 28 and 39 GHz for both DFF and CATR for $D = 2.78$ cm, the approximate dimension of a 1-x-4 antenna array for UE applications. As can be seen, the path loss of a DFF chamber is less than or equivalent to that of the CATR chamber at the same frequencies for the same DUT.

		28 GHz	39 GHz
DFF	D (cm)	2.78	2.78
	FF distance R (cm)	14.43	20.09
	Path loss (dB)	44.6	50.32
CATR	D (cm)	2.78	2.78
	Reflector size (cm)	5.56	5.56
	Focal length R (cm)	19.46	19.46
	Path loss (dB)	47.2	50.05

Figure 6. DFF and CATR path loss are compared at 28 and 39 GHz for $D = 2.78$ cm.

Conclusion

The choice of OTA test methods, DFF versus CATR for example, has significant implications on capital cost and path-loss performance. For UE DUTs that have built-in antenna arrays with $D \leq 3.7$ cm in well-known locations inside the DUT, the DFF OTA test method yields capital-expenditure savings that are up to 10 times greater than the CATR method, with equivalent or lower path loss.

Understanding 5G Millimeter Wave Beamforming Test

Previously published at RF Globalnet on April 15, 2019

5G devices operating at millimeter wave frequencies contain two or more tiny antenna arrays, each array containing four or more patch antennas. The spatial beam direction of the antenna array can be changed on the fly by simply changing the gain and phase of each patch antenna. This dynamic change of the beam direction is called beamforming, and beamforming performance needs to be characterized in the R&D lab and verified in DVT.

This article explains beamforming in the context of 5G NR specifications, and introduces beamforming characterization and beamforming verification test. However, before we discuss beamforming testing, let us first define some basic beamforming terms, as illustrated in Fig. 1:

Beam – The “beam” is the main lobe of the radiation pattern of an antenna array.

Beam center direction – This is the direction equal to the geometric center of the half-power contour of the beam.

Beam peak direction – This is the direction where the maximum Equivalent Isotropically Radiated Power (EIRP) is found.

Beam direction pair – This is the data set consisting of the beam center direction and the related beam peak direction.

Beamwidth – This is the beam which has a half-power contour that is essentially elliptical; the half-power beamwidths in the two pattern cuts that respectively contain the major and minor axis of the ellipse.

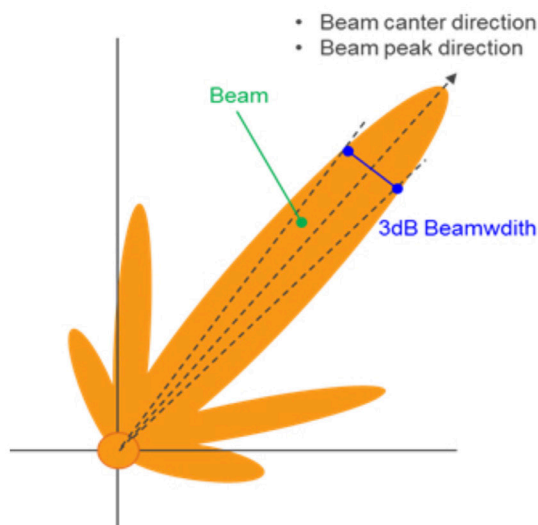

Fig. 1: Beamforming Terms

The 5G 3rd Generation Partnership Project (3GPP) NR specification [2] has defined four frequency operating bands (Table 1), all of which are time division duplex (TDD). TDD is beneficial to beamforming because of the uplink (UL) and downlink (DL) channel reciprocity. The network equipment can use the UL channel to ascertain the DL channel characteristics, and then chose the optimum beamforming for the DL signal to the UE.

Operating Band	Uplink (UL) operating band BS receive UE transmit	Downlink (DL) operating band BS transmit UE receive	Duplex Mode
	F _{UL_low} – F _{UL_high}	F _{DL_low} – F _{DL_high}	
n257	26500 MHz – 29500 MHz	26500 MHz – 29500 MHz	TDD
n258	24250 MHz – 27500 MHz	24250 MHz – 27500 MHz	TDD
n260	37000 MHz – 40000 MHz	37000 MHz – 40000 MHz	TDD
n261	27500 MHz – 28350 MHz	27500 MHz – 28350 MHz	TDD

Table 1: Table 5.2-1 of the 3GPP NR Specification [2]

Fig. 2 shows a user equipment (UE) device (e.g., smartphone) with two built-in 5G mmWave modules, each containing a 1x4 patch antenna array and four dipole antennas. For the following discussion, we will consider either the module or the final product as the device under test (DUT). For the example shown, each patch antenna element can have a vertical (V) or horizontal (H) polarization radiation pattern, which transmits or receives electromagnetic waves in either the vertical or horizontal direction.

Beamforming tests of DUTs — such as smartphones, tablets, mobile hot spots, fixed wireless access (FWA) terminals, etc. — usually are performed in a controlled environment, inside an over-the-air (OTA) chamber [3]. Understanding OTA link budget calculations [4] is a critical prerequisite before venturing into beamforming test.

When the antenna module is inside the final product (e.g., the smartphone), the antenna radiation pattern can be altered slightly due to the interaction with the final product enclosure materials and other surrounding components. Thus, the antenna performance, including its beamforming characteristics, needs to be tested using an appropriate OTA chamber of size, architecture, and shielding performance that ensures accurate antenna radiation pattern measurements.

Beamforming testing can be subdivided into two broad categories: beamforming characterization and beamforming verification.

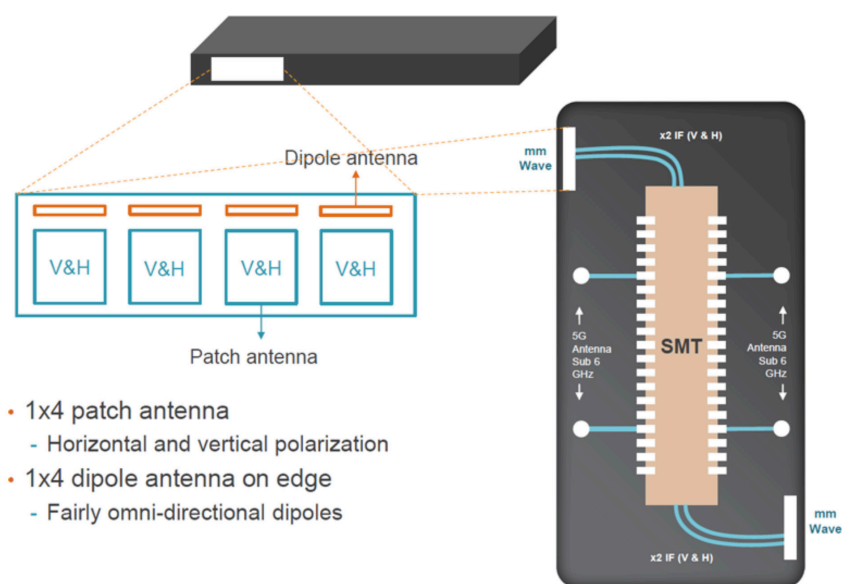

Fig. 2 — User Equipment Device with mmWave Antennas

Beamforming Characterization

Beamforming characterization aims to find the proper phase angle and gain value for each antenna element in order to achieve the desired pattern and direction for the specific DUT design in either its module or final product form. Thus, a beamforming “codebook” needs to be generated that contains the phase angle and gain for each antenna array required to generate a beam in a specific spatial range direction.

Beamforming characterization can be performed using either a CATR or DFF chamber [3], depending on the size of the DUT and its antenna array aperture [4]. The main requirements are that the geometric center of the DUT is placed at the center of the test zone and that the DUT is entirely enclosed in the “quiet zone.” Beamforming codebooks are then characterized and optimized, taking into account each specific antenna design (e.g., dipole, patch antenna arrays, etc.) and the end product system characteristics (enclosure material, antenna locations, etc.). And, since the OTA chamber used for this example comes equipped with a DUT positioner mechanism (a common feature on many OTA test chambers), the DUT can be rotated at various angles while the beam is continuously steered towards the zenith test antenna inside the OTA chamber.

Beamforming characterization can be performed with both VNA and VSA test equipment. However, VNA test equipment has some limitations:

- It requires a “breakout board” to route the IF signals from the VNA to the millimeter wave module. This represents a design and test inconvenience as this board, and accompanying test fixtures, need to be designed.
- Two ports are required: one for the “reference” IF signal and one for the RF measured signal.
- A final product cannot be tested with the VNA as there is no way to access the internal interconnections to the millimeter wave module.

A better approach for beamforming characterization is using a VSA, whose beamforming characterization advantages include:

- Both the module and the final product can be characterized, as there is no need to access the internal millimeter wave signal’s interconnections.
- No need for a breakout board and related test fixtures.
- Only one port is required (versus two ports with a VNA) for measuring the OTA millimeter wave signal.
- A VSA offers significant savings on capital investment, as only one piece of equipment is needed for both beamforming characterization and beamforming verification.

In order to achieve VSA testing benefits, “DUT assist” is needed, since the “reference” IF signal now is generated directly from the internal 5G modem (rather than from a VNA). The DUT’s internal 5G modem sets the respective phase and gain for each of the antenna array elements (Fig. 2) and the resulting beam’s signal characteristics are measured and analyzed using the VSA equipment.

Beamforming Verification

The design verification testing (DVT) stage usually requires that a larger sample of DUTs are tested to confirm that the DUT's beamforming is performing as expected. To achieve this, a subset of the beamforming codebook can be used for "corner case" testing.

Beamforming verification usually is performed using a direct far field [3] (DFF) OTA chamber. Such a setup is very simple and can be used for both module and UE final products.

During beamforming verification, it is the DUT itself that sets the specific phase and gain for each antenna element required to generate a beam in a certain direction (again, using a subset of the beamforming codebook). Thus, only one port is required in the VSA equipment. And, as explained earlier, since the OTA chamber has a DUT positioner mechanism built-in, the DUT can be rotated at various angles while the beam is continuously steered towards the zenith test antenna inside the OTA chamber.

Since a VSA is required for beamforming verification anyway, the test engineer can save significant capital expenditures by using a VSA for both beamforming characterization and beamforming verification, as explained earlier.

Conclusions

Beamforming increases network capacity, increases coverage due to high gain beams, and saves power, as the antenna elements not contributing to the main beam can be turned off. Beamforming codebooks are characterized at the "beamforming characterization" stage and fine-tuned for optimal performance. Beamforming characterization with VSA is much simpler and economical than with a VNA.

LITEPOINT

© 2019 LitePoint, A Teradyne Company.
All rights reserved.

TRADEMARKS

LitePoint and the LitePoint logo are registered trademarks of LitePoint Corporation. All other trademarks or registered trademarks are owned by their respective owners.

RESTRICTED RIGHTS LEGEND

No part of this document may be reproduced, transmitted, transcribed, stored in a retrieval system, or translated into any language or computer language, in any form or by any means, electronic, mechanical, magnetic, optical, chemical, manual, or otherwise, without the prior written permission of LitePoint Corporation.

DISCLAIMER

LitePoint Corporation makes no representations or warranties with respect to the contents of this manual or of the associated LitePoint Corporation products, and specifically disclaims any implied warranties of merchantability or fitness for any particular purpose. LitePoint Corporation shall under no circumstances be liable for incidental or consequential damages or related expenses resulting from the use of this product, even if it has been notified of the possibility of such damages.

If you find errors or problems with this documentation, please notify LitePoint Corporation at the address listed below. LitePoint Corporation does not guarantee that this document is error-free. LitePoint Corporation reserves the right to make changes in specifications and other information contained in this document without prior notice.

CONTACT INFORMATION

180 Rose Orchard Way
San Jose, CA 95134
United States of America

+1.866.363.1911
+1.408.456.5000

LITEPOINT TECHNICAL SUPPORT

www.litepoint.com/support

Doc: 1075-XXXX-001
June 2019 Rev 1