

APP NOTES

Wi-Fi 6 OFDMA Pre-correction Test Solution with IQxel-MW and IQsniffer

LITEPOINT

© 2019 LitePoint, A Teradyne Company.
All rights reserved.



Introduction

Wi-Fi 6, the next-generation Wi-Fi's connectivity technology based on the IEEE 802.11ax standard, promises greater capacity and more robust data transmission than previous Wi-Fi standards. Designed for improving capacity in environments with many connected devices such as stadiums and other public venues, Wi-Fi 6 provides 4x increase in user and system capacity over Wi-Fi 5. By allowing simultaneous access for multiple devices, 802.11ax lowers latency and enables more data transferred at once.

Wi-Fi 6 biggest technology change comes from the introduction of OFDMA (Orthogonal Frequency Division Multiple Access). OFDMA is a multi-user version of OFDM (used in earlier WLAN generations) where the Wi-Fi channel width is divided among multiple users who simultaneously exchange data with the Access Point using smaller sub-channels called resource units (RU). The 802.11ax standard borrows this technology from LTE networks to deliver a significant breakthrough in user capacity.

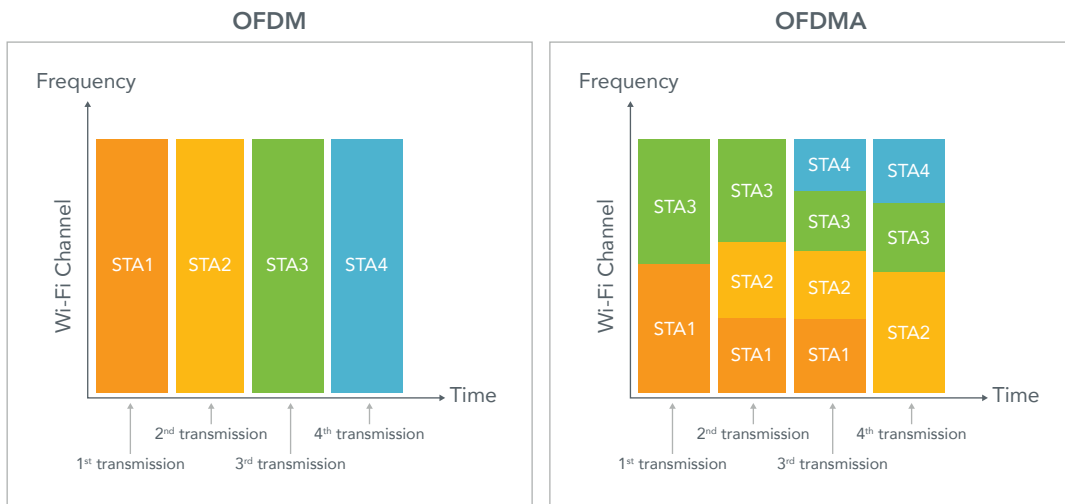

Figure 1 OFDM vs. OFDMA comparison

While OFDMA has long been in use in 4G/LTE networks, it is the first time it is being applied to the crowded and chaotic unlicensed bands in which Wi-Fi operates. This presents some unique testing challenges as OFDMA introduces the need for synchronization between the Wi-Fi client stations (STA) and the Access Point (AP), in terms of timing, frequency and power. The paragraphs below give a brief overview of the downlink and uplink OFDMA mechanisms.

In the downlink direction, traffic is transmitted from the Access Point to the Stations. DL-OFDMA transmission from the AP bundles together in different sub-channels (RU) data for multiple stations in a single transmission. On the receiving side, client devices tune their radios to receive their respective data on their assigned RU. For DL-OFDMA, the AP is in control of the transmissions, and the Stations are receiving traffic.

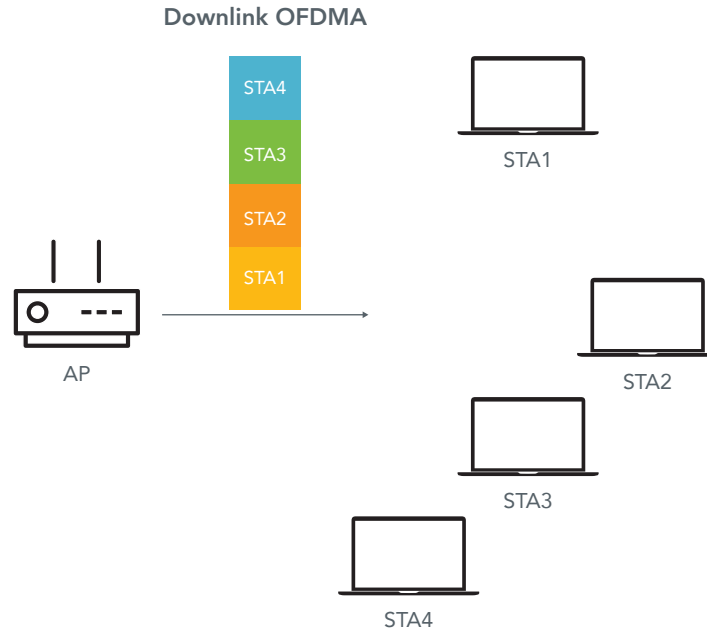

Figure 2 Downlink OFDMA transmission

In the uplink direction, traffic is transmitted from the Stations to the AP. For UL-OFDMA, the process described above is reversed. Multiple STA transmit simultaneously on their respective pre-assigned sub-channels, the AP is in charge of the coordination of simultaneous transmissions from the client stations. This synchronization is done by the transmission of a trigger frame. In response to the uplink transmission trigger frame, the client Stations have to tune their timing, frequency and power in order to participate in the upcoming transmission.

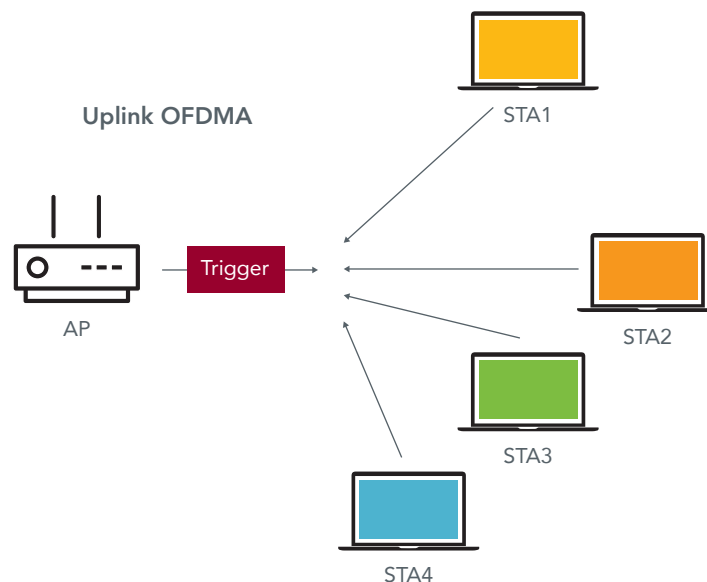

Figure 3 Uplink OFDMA transmission

The synchronization accuracy between AP and STAs determines the overall network capacity. Multiple users share the spectrum at the same time and interference between simultaneous users degrades the overall system capacity, therefore **verification of the compliance of the AP and client Stations to the requirements is critical.**

Timing requirements

The 802.11ax requirements mandate that STAs transmit within 400 ns of each other. First, in the downlink direction, the AP transmits a trigger frame providing synchronization to the STAs. This frame also contains information about the OFDMA sub-carriers RU assigned to each STA. The participating STAs need to start transmission of the uplink signal after a specified time interval SIFS (short interframe space) of $16 \mu s \pm 400 \text{ ns}$ after the end of the trigger frame.

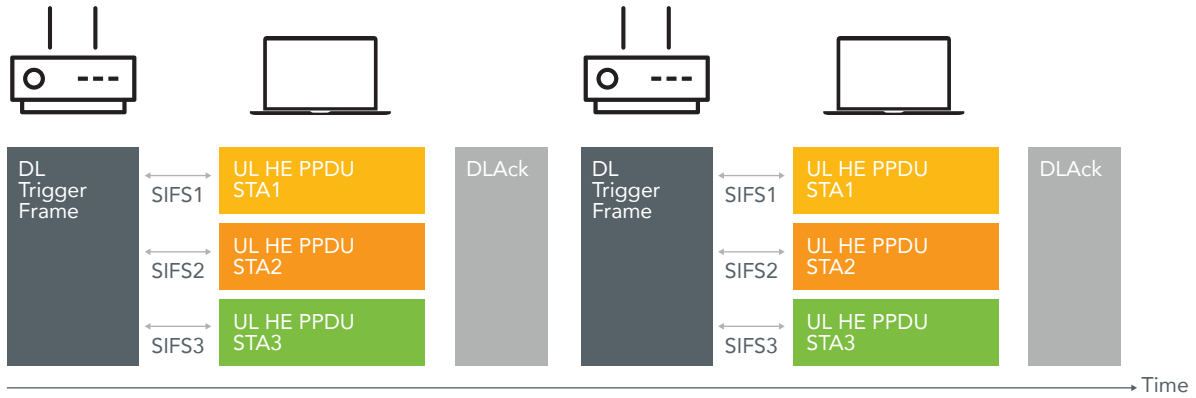

Figure 4 Uplink OFDMA transmission timing

Frequency requirements

In order to ensure that all STAs operate within their allocated RU and in order to prevent inter-carrier interference (ICI) between the client Stations transmitting simultaneously, the STAs need to pre-compensate for carrier frequency offset (CFO) error, based on the trigger frame received from the AP. The 802.11ax standard requires a residual CFO error after compensation to be less than 350 Hz.

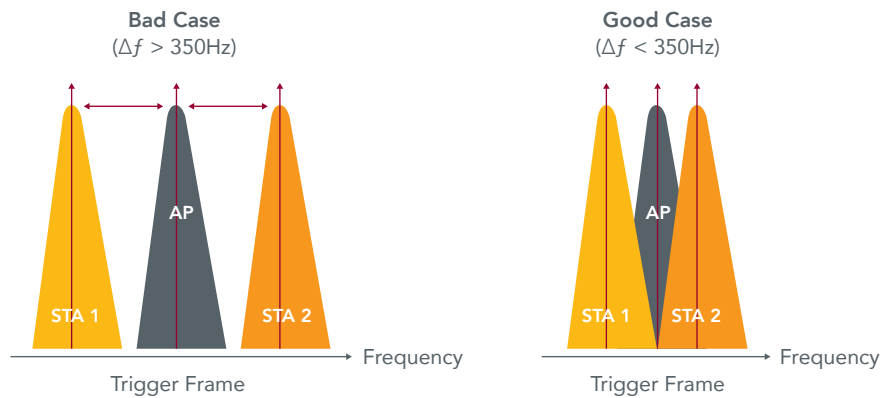

Figure 5 Interference between Stations

Power control requirements

When traffic is transmitted between the AP and STAs that are located at various distances, power control is needed to ensure that STAs closer to the AP do not drown out users farther from the AP transmitting simultaneously. The 802.11ax standard requires the STAs to adjust their power based on the estimated path loss between AP and Stations. Devices closer to the AP transmit less power while devices farther away transmit more power to achieve the same received power at AP receiver considering the path loss. There are 2 classes of devices defined in the standard based on how accurately they can control their power. The class A devices control their transmit power within ± 3 dB and the class B devices control their power within ± 9 dB.

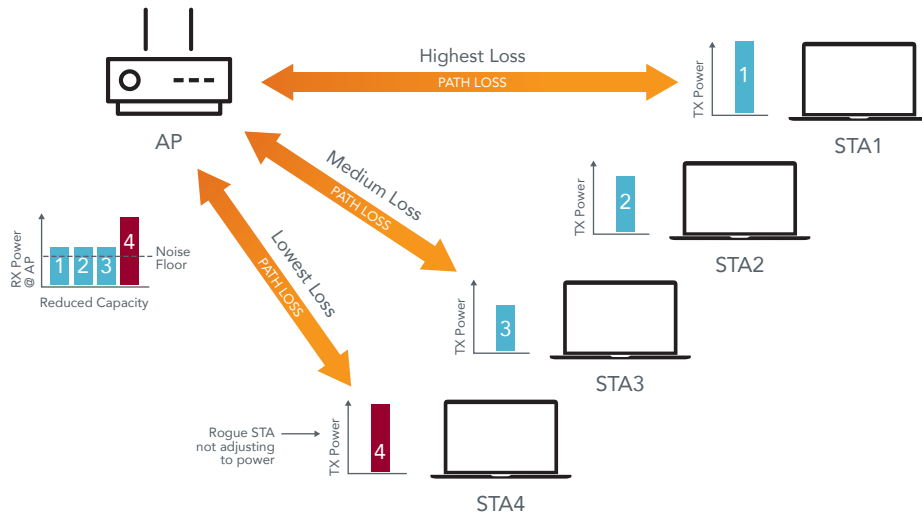

Figure 6 Power Control

OFDMA Pre-correction Test

The validation of OFDMA mandates a set of features not previously required from Wi-Fi test equipment, as timing, frequency and power control become critical parameters for optimal 802.11ax operation. Verification of compliance requires real-time capture of Wi-Fi traffic at the physical layer and monitoring of both uplink and downlink traffic directions to detect downlink trigger frame transmission and perform analysis of uplink OFDMA packets for parametric measurements of timing, frequency and power for each of the RUs involved in the uplink transmission. OFDMA compliance tests include verification of frequency, timing and power pre-correction tests, designed to ensure that Wi-Fi 6 devices participating in OFDMA transmission interoperate and work well together. LitePoint's IQxel-MW or the newer generation IQxel-MW 7G test platforms with IQsniffer (Wi-Fi traffic sniffer) software option provide these test capabilities by monitoring transmissions between AP and client Stations under test.

IQxel-MW Platform Overview

IQxel-MW is a comprehensive test solution delivering high performance verification for the most popular wireless connectivity standards including 802.11, Bluetooth, DECT and ZigBee. In addition to legacy Wi-Fi standards, it supports testing of all key 802.11ax (Wi-Fi 6) and MIMO specification enhancements. The IQxel-MW series is available in three configurations:

- IQxel-M2W with 2 ports, 2 Vector Signal Analyzer, Vector Signal Generator (VSA/VSG)
- IQxel-M8W with 8 ports, 2 VSA/VSG
- IQxel-M16W with 16 ports, 4 VSA/VSG

The platforms support up to 2x2, 4x4 MIMO respectively and are scalable to 8x8 true MIMO testing.

Used in Over the Air (OTA) or conducted test setup, the IQxel-MW VSA capabilities provide the RF PHY layer parametric measurements necessary for OFDMA pre-correction tests.



Figure 7 IQxel-M2W

IQxel-MW 7G Platform Overview

IQxel-MW 7G test platform is an evolution of the IQxel-MW designed to provide an extended frequency range support for the 6 GHz frequency band with frequency up to 7.3 GHz.



Figure 8 IQxel-M2W 7G

Wi-Fi Traffic Sniffer Overview

IQsniffer software option for the IQxel-MW and IQxel-MW 7G product family provides an integrated implementation capable of capturing and analyzing complex interactions between Wi-Fi 6 OFDMA participants. Providing simultaneous analysis at the MAC and RF PHY layers for all users and streams, it simplifies troubleshooting and debugging of Wi-Fi 6 MU-MIMO and OFDMA features. This allows engineers to achieve faster time to market with Wi-Fi 6 compliant devices.

The IQxel platform's high residual EVM performance ensures that parametric measurements truly measure the Device Under Test (DUT) performance, and not the uncertainty in the measurement setup.

PHY layer and MAC layer traffic analysis parameters include:

- PHY layer parametric measurements (EVM, Power, Spectrum) on a per-stream and per-user basis.
- Timing information with nanoseconds accuracy for trigger based timing analysis.
- PPDU information with HE-SU, HE-MU, HE-TRIG and FEC type.
- MAC layer information with packet type, sub-type and MAC addresses for station identification and full PSDU bits capture.

During the test, the AP under test transmits downlink trigger frames at a specified interval containing information on client stations RU allocation, MCS and Target RSSI. In response the STA generates UDP traffic (HE TB PPDU) in the uplink direction to the AP. Uplink and downlink packets exchanged between the AP and STA under tests are captured by the IQxel tester.

The IQsniffer real-time analysis function uses information decoded from the trigger frame to decode uplink traffic and provide HE-TRIG Frame PPDU measurements. Analysis of the HE-TRIG determines the accuracy of the absolute transmit power, the CFO error relative to the Trigger PPDU frame and delay by measuring the gap from falling edge of Trigger PPDU to rising edge of HE-TRIG PPDU frame.

For easy analysis, a CSV output file is generated containing the frame capture information with timing, frequency offset, EVM and power measurements along with identification information like MIMO Stream#, MAC addresses and RU information.

Packet information results can be exported in CSV format for post-processing, or IQramp data analysis software can be used to quickly visualize the results and then dynamically analyze and plot the CSV packet data.

Figure 9 below shows an example of HE TB PPDU CFO pre-correction plotted with IQramp. The frequency error must remain below 350 Hz for compliance. Outliers can be quickly spotted using IQramp customized plots.

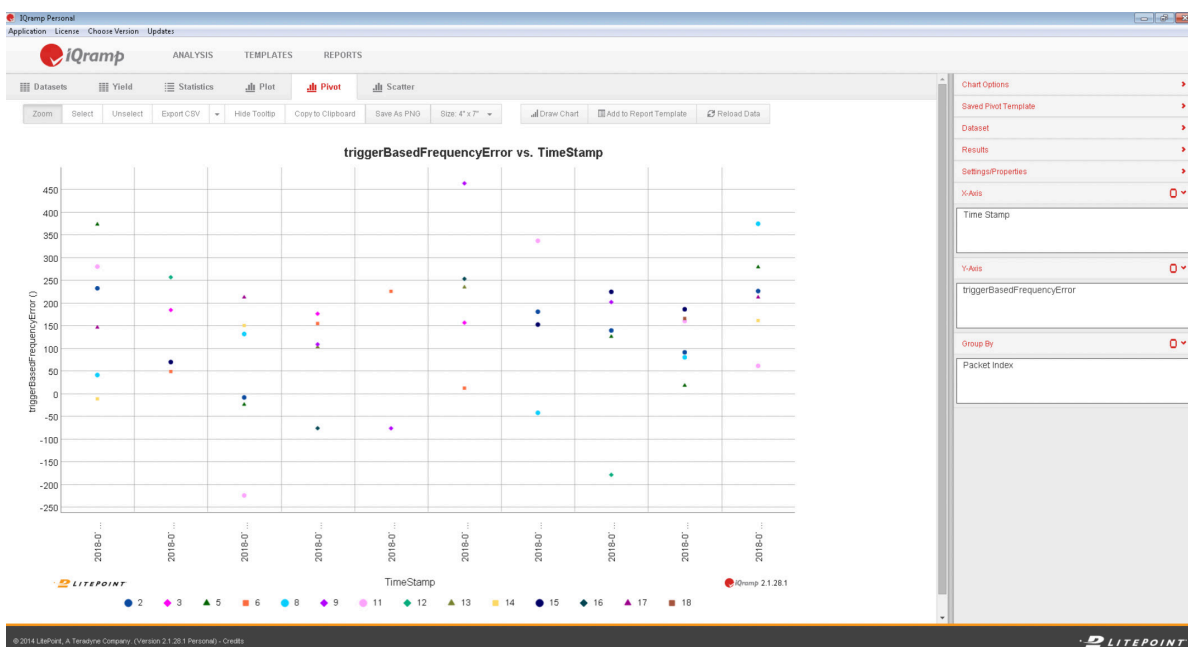

Figure 9 CFO error with IQsniffer

Figure 10 shows HE TB PDU SIFS Timing Measurement plotted with IQramp, compliance requires $16 \mu\text{s} \pm 400 \text{ ns}$.

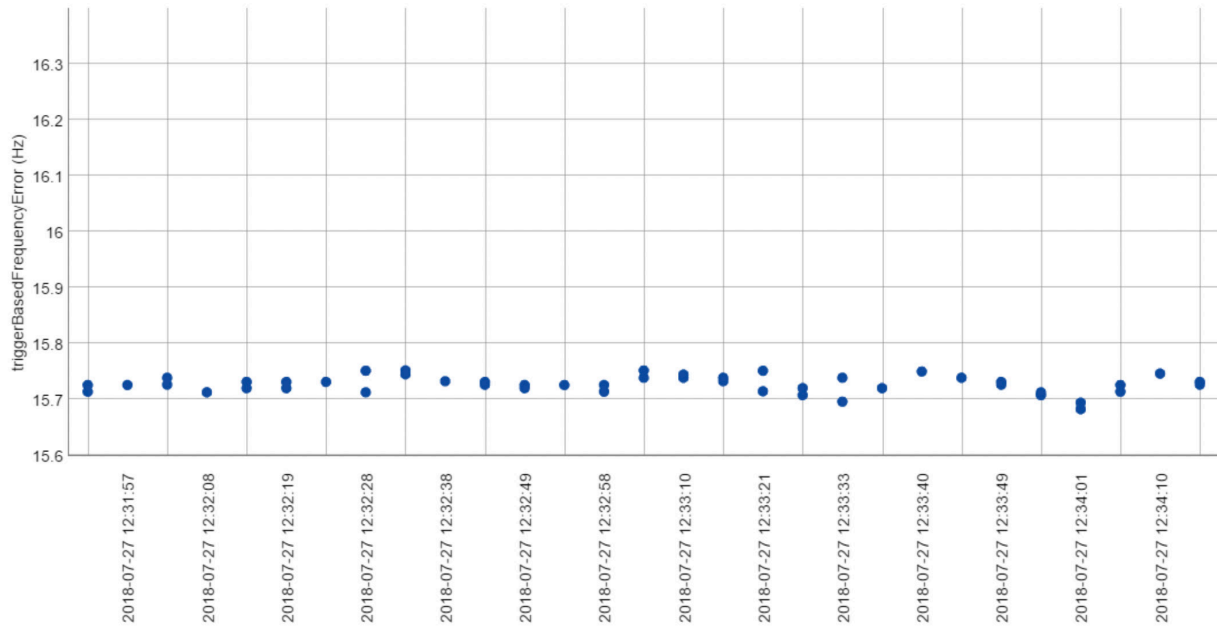

Figure 10 SIFS timing measurement with IQsniffer

OFDMA Pre-correction Test Configuration

Two test configuration options are possible. The IQxel platform can be used in conductive test configuration with directional couplers or in over the air (OTA) analysis in an RF chamber. Conducted and OTA configurations are described in the figures below.

Conducted Test Configuration

The conducted test configuration ensures that the RF paths from AP under test and STA under test to IQxel are identical, this ensures accurate timing measurement for SIFS because propagation delays in each direction are cancelled out.

The utilization of directional couplers (DC) guarantees signal quality and accuracy of transmit power measurements, and sufficient SNR for CFO measurements.

Figure 11 shows conducted test setup for SISO test. For MIMO tests, similar configuration can be used with connection to multiple ports on the IQxel tester. A similar configuration can also be used for multiple STA DUT connected to a single AP.

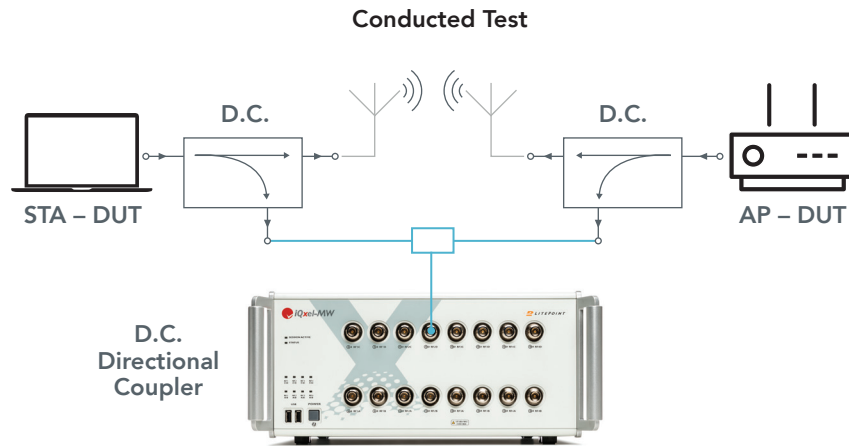

Figure 11 Conducted Test Configuration

Over the Air Test Configuration using RF Chamber

For this setup, the STA under test, AP under test and IQxel tester are placed in an RF chamber. IQxel-MW captures packets using an antenna connected to its RF ports. The location, distance between AP and STA and antenna polarities can be adjusted to achieve the desired path loss.

Over the Air Test using RF Chamber



Figure 12 Over the Air test Configuration

Conclusion

Wi-Fi 6, based on the IEEE 802.11ax standard, relies on complex OFDMA technology to achieve greater capacity in environments with high device density, like airports or stadiums. With multiple devices sharing the spectrum and transmitting simultaneously, one bad actor can ruin the transmission for all other devices in the network. More than ever verification of compliance to the standard is needed to ensure that Access Points and client Stations interoperate and work well together.

LitePoint's IQxel test platform and Wi-Fi traffic sniffer provide an integrated implementation capable of capturing and analyzing complex interactions between Wi-Fi 6 transmission participants. Providing simultaneous analysis at the MAC and RF PHY layers for all users and streams, it simplifies troubleshooting and debugging of Wi-Fi 6 MU-MIMO and OFDMA features. Verification of Wi-Fi 6 compliance is simplified and devices can achieve faster time to market

Ordering Information

Running IQsniffer on the IQxel family requires the following software licenses installed on the IQxel-MW or IQxel-MW 7G platform:

Option	Comments
802.11ac VHT80 (80 MHz signal bandwidth) software license	Required for 802.11ac analysis
802.11ac VHT160 (80+80 MHz and 160 MHz signal bandwidth) software license	Required for 80+80 MHz or 160 MHz channel analysis
802.11ax software license	Required for 802.11ax analysis
WLAN MIMO software license. Enables MIMO option for 802.11n, 802.11ac, and 802.11ax	Required for MIMO traffic analysis
Wi-Fi Traffic Sniffer software license	IQsniffer software license

LITEPOINT

© 2019 LitePoint, A Teradyne Company.
All rights reserved.

TRADEMARKS

LitePoint and the LitePoint logo are registered trademarks and IQxel-MW is a trademark of LitePoint Corporation. Microsoft Windows is a registered trademark of Microsoft Corporation in the United States and/or other countries. All trademarks or registered trademarks are owned by their respective owners.

RESTRICTED RIGHTS LEGEND

No part of this document may be reproduced, transmitted, transcribed, stored in a retrieval system, or translated into any language or computer language, in any form or by any means, electronic, mechanical, magnetic, optical, chemical, manual, or otherwise, without the prior written permission of LitePoint Corporation.

DISCLAIMER

LitePoint Corporation makes no representations or warranties with respect to the contents of this manual or of the associated LitePoint Corporation products, and specifically disclaims any implied warranties of merchantability or fitness for any particular purpose. LitePoint Corporation shall under no circumstances be liable for incidental or consequential damages or related expenses resulting from the use of this product, even if it has been notified of the possibility of such damages.

If you find errors or problems with this documentation, please notify LitePoint Corporation at the address listed below. LitePoint Corporation does not guarantee that this document is error-free. LitePoint Corporation reserves the right to make changes in specifications and other information contained in this document without prior notice.

CONTACT INFORMATION

180 Rose Orchard Way
San Jose, CA 95134
United States of America

+1.866.363.1911
+1.408.456.5000

LITEPOINT TECHNICAL SUPPORT

www.litepoint.com/support

Doc: 1075-0428-001
September 2019 Rev 1